

**MOD 200**

**Technical Booklet**

**Collectif 17h25**

# Disclaimer

"Standard Structures" — MOD 200 is a project distributed under **Creative Commons CC BY-NC-ND 4.0 licence**.



This licence authorises the reuse of content, subject to attribution, but prohibits any modification of protected elements.

As such, **Collectif 17h25** makes available:

- ↳ the catalogue
- ↳ the manufacturing drawings
- ↳ CAD models
- ↳ mechanical characterisation data for strength calculations of the structural elements of the set made from these components.

Any entity or individual using these elements is **fully responsible for their use**.

In particular, it is their responsibility to ensure:

- ↳ compliance with **best practices in construction**
- ↳ **calculations and checks** appropriate to the end user's specifications.

This booklet is intended **to support this process**.

The **drawings, CAD models and mechanical characteristics** of the MOD 200 product can be downloaded free of charge via the following link, where numerous **examples of applications and accessories** are also available.

→ <http://mod200.collectif17h25.org>



"Standard Structures" is a **collective and evolving project**.

As research is still ongoing, **changes and updates** may occur as the project evolves and is used.

You are invited to contribute to the project by sharing your designs, research and feedback as members of the **"MOD 200 Community"**.

Specific instructions for using MOD 200 will be published at a later date; however, this documentation allows users to implement the system.

*This booklet was realised by the Collectif 17h25. It must be used in accordance with the technical and safety regulations applicable to removable structures within the framework of the "manufacturing and implementation process". The Collectif 17h25 cannot be held liable for any and all direct or indirect, material, immaterial or financial damages resulting from a defect in the design, manufacture, installation or maintenance of the demountable structures, particularly towards third parties under the terms and conditions provided for by applicable case law.*

→ [www.collectif17h25.org](http://www.collectif17h25.org)



# Introduction

---

The integration of MOD 200 into sets requires a period of adaptation by technical crews. New practices must be implemented: these affect the organisation of work, call on collective intelligence and may challenge long-established habits.

In this document, the technical teams at Collectif 17h25 share their feedback and expertise from the first major research phase, which began in 2021 and was completed on 31 December 2025.

To understand the motivations behind the project, as well as its challenges in terms of sustainability, durability and economy, we recommend referring to the MOD 200 — General Booklet.

This research received a France 2030 grant ("Supporting green alternatives" call for proposals), led by the French Ministry of Culture.

The overall budget of €900,000 was co-financed by the five venues that initiated the project.

Disclaimer	01
Introduction	02
Origin	05
The Module	05
<b>01   Product development process</b>	<b>07</b>
What needs to be standardised?	07
Modular construction specifications	08
Ambition at the end of the research period	08
Method	08
Experimentation and testing	08
<b>02   MOD 200 system</b>	<b>10</b>
Bars and trusses	10
Profile/material	10
Cutting and drilling	10
Assembly and relief holes	10
Truss families (2D components)	11
<b>03   Design</b>	<b>14</b>
General Principles for Set Design	14
Accessories	14
<b>04   Assemble</b>	<b>16</b>
Assembling	16
Hybridisation	16
Assembly principles	16
<b>05   Dimensioning/Calculation</b>	<b>18</b>
Characterisation study	18
Loading table and charts	18
Mechanical characteristics	18
<b>06   Manufacturing</b>	<b>19</b>
Regulatory framework	19
Marking	19
Manufacturing recommendations	19
Costs	19
<b>07   Control/Maintenance</b>	<b>21</b>
<b>08   Storage/Sharing</b>	<b>21</b>
Conclusion	22
FAQ — MOD 200	23
Project identity	24



## Origin

Committed to structural changes in favour of **ecological transition**, the **Collectif 17h25** was formed in 2019, bringing together the **Théâtre du Châtelet**, the **Opéra National de Paris**, the **Opéra National de Lyon**, the **Festival d'Aix-en-Provence** and the **Théâtre Royal de La Monnaie** in Brussels.

After several meetings, the partners concluded that **standardising opera set elements** was a **major lever for reducing impact**, based in particular on:

- ↳ their respective initiatives already underway
- ↳ their publications
- ↳ their inventory management
- ↳ and their budgetary approaches.

Aware of their structuring role in the sector, they also identified that these developments could **benefit all players in the industry more broadly**.

In order to initiate a process of reflection likely to produce **concrete results**, the Collective has commissioned an external study aimed at:

- ↳ assessing **reuse and standardisation practices** within the five venues of the Collective.
- ↳ exploring existing or emerging **technical solutions**
- ↳ proposing **draft targeted solutions**.

This approach corresponds to the **preliminary study phase**.

Finalised in **2022**, the preliminary study report formulated technical proposals as well as **methodological recommendations** to support these transformations. It enabled **operational entry points** to be identified and convinced all partners to commit to a **collective research approach**, aimed at changing practices while mobilising their cross-disciplinary skills.

Following these reports, the Collective won the **France 2030 call for proposals**, enabling it to mobilise **human and material resources** to carry out genuine **Research & Development**, to be deployed over the **2023–2025** period.

To this end, **five operational committees**, systematically composed of members from the five venues and coordinated jointly, were set up. They quickly identified the **first foundation of the project: the module**.

## The Module

The adoption of a baseline measure aimed at harmonising the design of components is not unique to the Collective.

However, in the context of this study, the rigorous application of this principle emerged as a **structuring principle**:

The definition of a **common unit** makes it possible to generate a set of **standardised** dimensions, promoting:

- ↳ assembly connections
- ↳ element compatibility
- ↳ multiple simplifications

all of which contribute to a **reduction in material requirements** in the set manufacturing.

The module chosen by the Collective is based on the **metric system** and defines a **reference pitch of 200 mm**. The name "**MOD 200**" thus became the natural choice during its deployment.

This dimension — **200 mm** — is adapted to the scale of common constructions in the sector, generally integrated into:

- ↳ Proscenium arch with a maximum height of around **12 m** (and often less)
- ↳ openings up to **20 m** wide.

It allows the majority of common applications to be handled using a **TRUSS**.

Symbolically and practically, the Collectif 17h25 also adopted the **200 mm step height** as the standard for its stock of staircases, making them **compatible with all future constructions**.

The **derived dimensions**, obtained by multiplying or dividing the module, generate a wide range of possibilities **for accessorising and assembling**, allowing for harmonious connections between the many elements needed to build a set on stage.

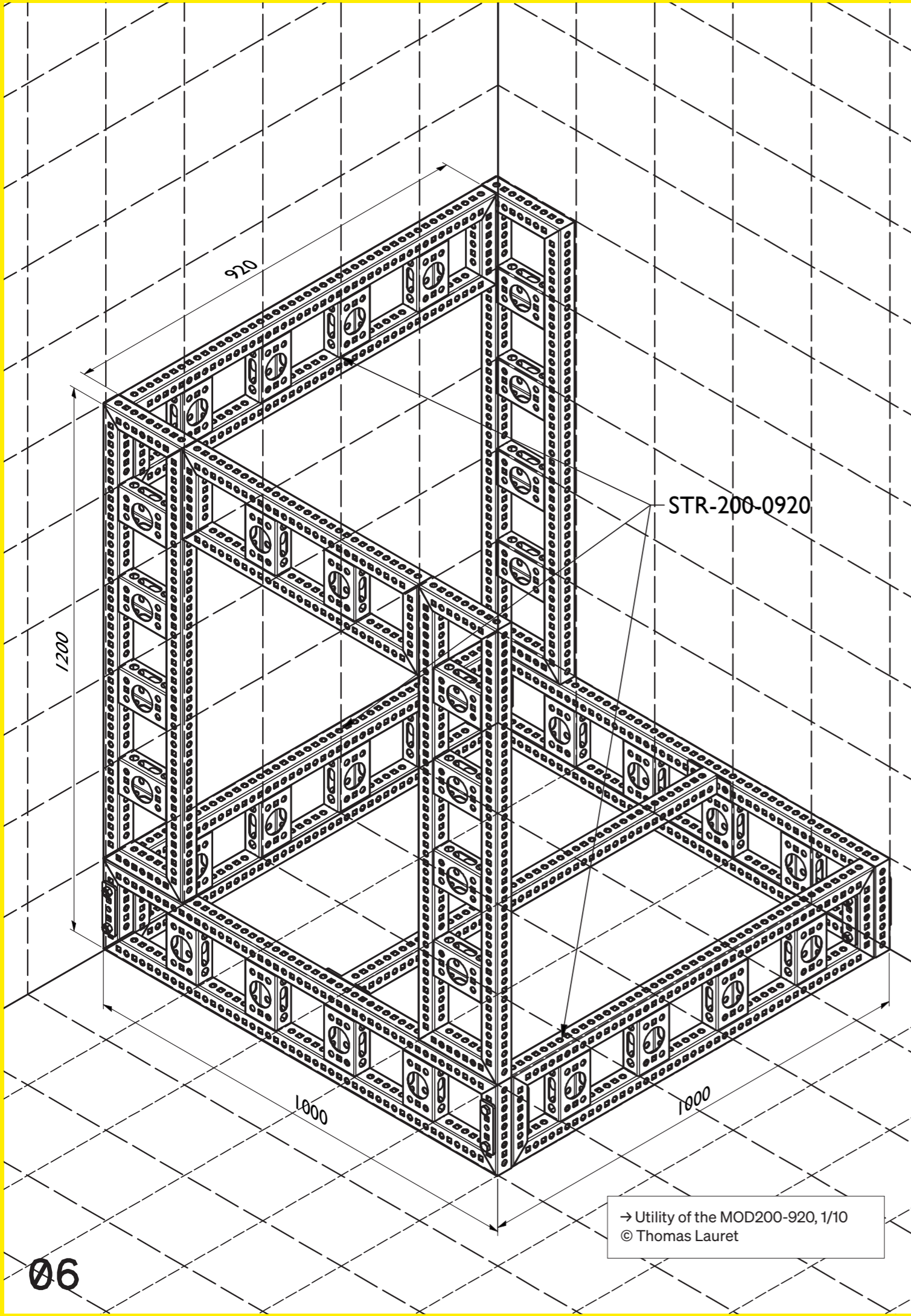

# 01 | Product development process

The research was based on a **structured methodology**, relying on operational committees and **continuous communication between the venues**. In particular, it revolved around **working "labs"** — meetings and workshops — which enabled significant progress to be made.

Wishing to avoid **reinventing existing solutions**, the Collective also investigated solutions within the industry, commissioning a study entitled **"State of the art in France and Europe of practices in the repertoire and standards in scenography"** — conducted in 10 theatres and opera houses.

This work revealed that, despite numerous initiatives, relevant internal solutions and strong interest in comprehensive approaches, **no standardisation solution** had yet been widely adopted in the sector.

## What needs to be standardised?

The first labs explored various objects, including:

- ↳ access **staircases**
- ↳ wall stabilising **braces**
- ↳ transport **trolleys**
- ↳ and other elements.

**Truss structures**, used for rigging, flying or creating scenes, podiums and bleachers — very common in the events sector — were not an immediate priority: their limited use in the performing arts, as well as the incompatibility between existing commercial standards, led the Collective 17h25 to initially rule them out. On the other hand, the need for **standardised horizontal surfaces ("rostrum")** had already been identified by many stakeholders.

Although partially addressed by the acquisition of high-performance industrial stock, these solutions presented **similar compatibility issues**. Attention then quickly turned to **set structures**, for which few suitable solutions existed. The **stock scenery\***, often made of aluminium or wood — mainly intended for hanging drops and canvasses — was:

- ↳ developed locally
- ↳ lacking coordination between theatres
- ↳ and limited in its structural and three-dimensional capabilities.

*\*Stock scenery: all reusable items stored and used internally in theatres.*

The **large volumes of dedicated structures\*** produced within the Collective, as well as their **logistical impact** during tours and co-productions, have highlighted the need to rethink their repeated manufacture.

*\*Dedicated structure: an element manufactured for single use, designed to support a set, usually made of steel, aluminium or wood.*

The teams also evaluated the use of commercially available scaffolding structures as an alternative, before concluding that it would be beneficial to develop a specifically designed product that precisely meets the needs of users, locally available and intended to reduce or even eliminate long-distance transport. While several cross-cutting themes marked the research, the technical advisors — workshops, machinists, design offices and technical departments — quickly converged on a priority objective: the design of a reusable modular construction system.

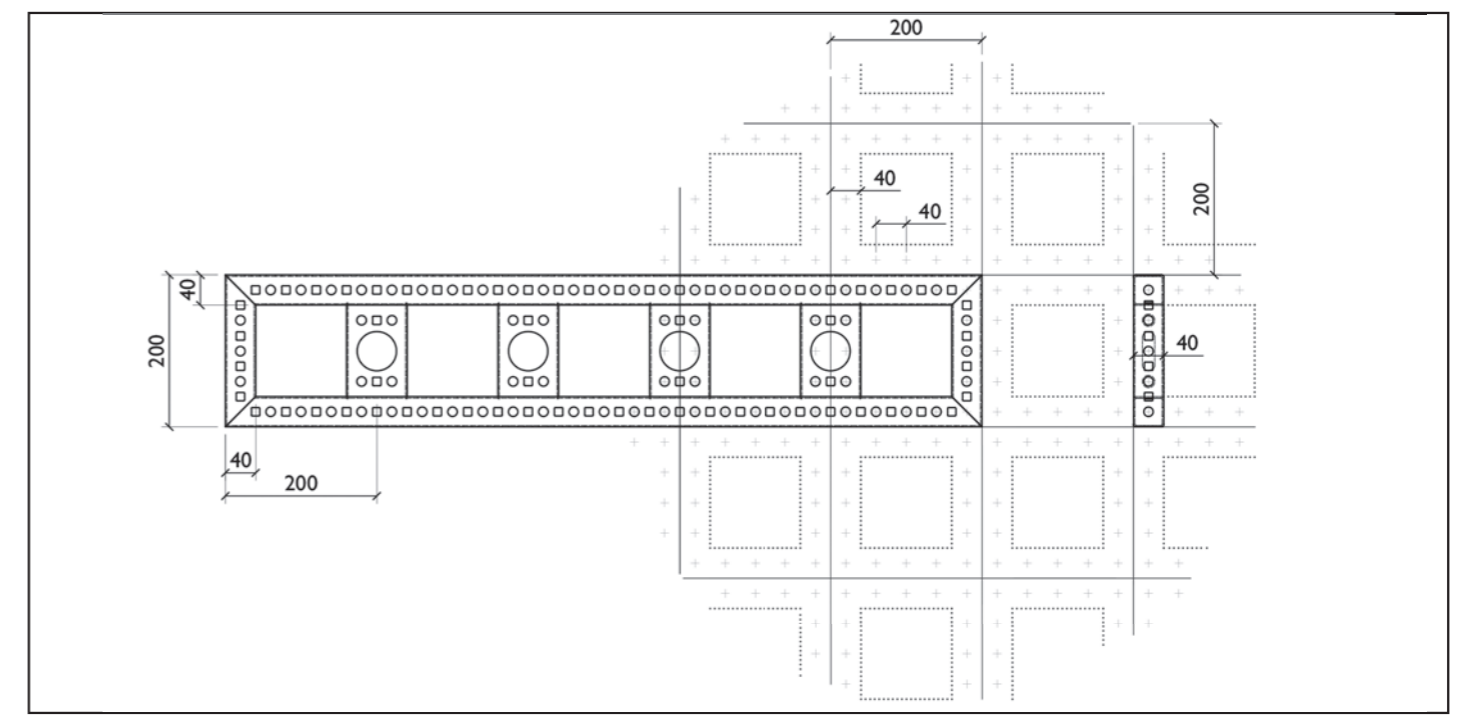

→ Modular grid and MOD 200-200, 1/10 © Thomas Lauret

# Modular construction specifications

The research primarily aims to establish a system that allows:

- ↳ **responding, either fully or partially, to all scenographic constraints** without compromising creative freedom;
- ↳ **designing and testing modular structures that can be dismantled and reused**, comparable in their logic of use to scaffolding systems;
- ↳ **using these structures for the non-visible parts** of the sets (the 'backstage'), without imposing any constraints on the surfaces visible to the audience;
- ↳ **incorporating criteria of durability, robustness and ergonomics**, taking into account handling constraints, the Labour Code (arduousness) and good professional practices;
- ↳ **determining the materials, manufacturing processes and surface treatments with the lowest possible environmental and social footprint**;
- ↳ **establishing future usage scenarios**, particularly in the context of touring and co-productions, in order to feed the analysis factors;
- ↳ **assessing the overall footprint of the proposed system** using a **Life Cycle Assessment (LCA)** and compare it with that of traditional dedicated structures;
- ↳ **adapting manufacturing methods** to the current specialisation of set construction workshops (metalwork, carpentry) in order to make **them accessible to as many people as possible**;
- ↳ **sharing the research results**, while distributing them under a *Creative Commons* licence that regulates their reuse.

# Ambition at the end of the research period

- ↳ **Gradually begin building up stocks**, mobilising all available manufacturing resources and budgets;
- ↳ **Promote the dissemination of the system** through pooling initiatives;
- ↳ **Aiming for the long-term elimination of the need to transport standardised structures**.

# Method

The research methodology draws on **system design** and **service design** resources. It relies on the **cross-functional skills** of numerous collaborators from different departments within the partner institutions. The entire process is **coordinated by an external coordination team**, which ensures methodological consistency and circulation of information. → For a more detailed description of this approach, please refer to the **General Booklet**.

# Experimentation and testing

## Research stages

The research was divided into **five phases**. The summary below aims to illustrate the **iterative decision-making process** that enabled the partners to gradually agree on the conclusions.

### ► Phase 1 — In-depth preliminary study and state of the art February 2023 — October 2024

Collective determination of the main topic: the Collective explores the **unitary system** through the module, draws up an exhaustive list of candidate items, shares local solutions and best practices, **solicits input from external actors** (Helsinki Opera, Union Des Scénographes, etc.), and draws on experiences from the sector at the European level. The question "**What needs to be standardised?**" is then answered. The research topic is launched: **modular construction**.

### ► Phase 2 — Prototyping April 2023 — March 2024

A **basic profile** is determined. The first samples are produced, followed by the **manufacture and testing of prototypes**: assembled beams, accessories, etc. Resistance test benches are carried out in-house. A **"Cubic Meter" demonstration prototype** is presented in Brussels. The members of the Collective handle and assemble the components, testing different parameters: access to bolt tightening, risks to fingers, speed of assembly, weight, assembly precision, choice of hardware, lifting equipment...

Simultaneously, the first **theoretical models of sets** were created. A **"style exercise"** mobilised the design offices, including a **classic contradictory variant**, created using a dedicated structure. These projections enabled the extraction of reference data: masses, transport volumes, costs.

The chosen scenario corresponded to a **common denominator among the partners**: a typical co-production involving **average transport frequency and distances** (internal and tour transport) for the five venues.

An **LCA** (Life Cycle Assessment) was then commissioned. It demonstrated that, in the scenarios studied and based on the data collected, the **modular system becomes sustainable between one and two reuses**. Designed to last, the MOD 200 proved to be well suited to its objectives.

### ► Phase 3 — Application in production April 2024 — June 2025

1 to 1 scale set **prototyping** begun with the deployment of the **MOD 200** in significant volumes. While the profile and module quickly gained consensus, **three variants of drilling and assembly hardware** were developed. These were tested in **four venues** and in **six productions** scheduled during one season.

This plurality of solutions gave rise to **lively debates** among the research protagonists, particularly regarding the **diameter of the drill holes**. Arguments about **strength** and **usability** were opposed, while machinists and workshops strongly emphasised the **ergonomic constraints of their trades**.

The product **must** be suitable for **all uses**, otherwise risking failure. Despite these tensions, which are an integral part of the project's history, the **MOD 200s remained compatible with each other** and fulfilled their essential function: **supporting the large sets for which they were designed**. The comparison of experiences, combined with cross-visits to the sets and workshops, then initiated the **final operational phase**.

### ► Phase 4 — Evaluations March 2025 — December 2025

Keen to ensure the calculable **mechanical resistance** of the proposed system — particularly with a view to its distribution — the Collective entrusted the **characterisation calculation of the profile** to an **external design office**. This stage also provided an opportunity to **compare and, if possible, decide between the three versions** developed previously. Initial results showed that the **drilling diameters have a very limited influence** on the overall performance of the system.

In order to eliminate any bias, the versions were compared according to several criteria: linear mass, assembly constraints, availability of hardware, cost per linear metre and per square metre. No strictly decisive criteria emerged from this comparative analysis. To reach a decision, **careful consideration of usage** and the use of **collective intelligence** became decisive. A few days before the end of the research period, **MOD 200 — Version 4** was **unanimously** adopted, establishing the **baseline standard** for this modular construction.

### ► Phase 5 — Communication March 2023 — March 2026

Throughout the research process, **meetings and publications** were held to present the progress made and collective decisions taken. These publications, entitled "**STD**", were distributed to internal collaborators and network partners, in order to **share methods** and **encourage the spread of the process** beyond the operational teams alone. At the end of this phase, **two summary booklets** were published and a **symposium to present the findings and open up the process** was organised and is due to take place on **5 March 2026** at the Opéra National de Paris. The objectives of this phase are to disseminate the method, share the results obtained, structure and expand the **MOD 200 community** and take a further step towards **reducing environmental impacts**.

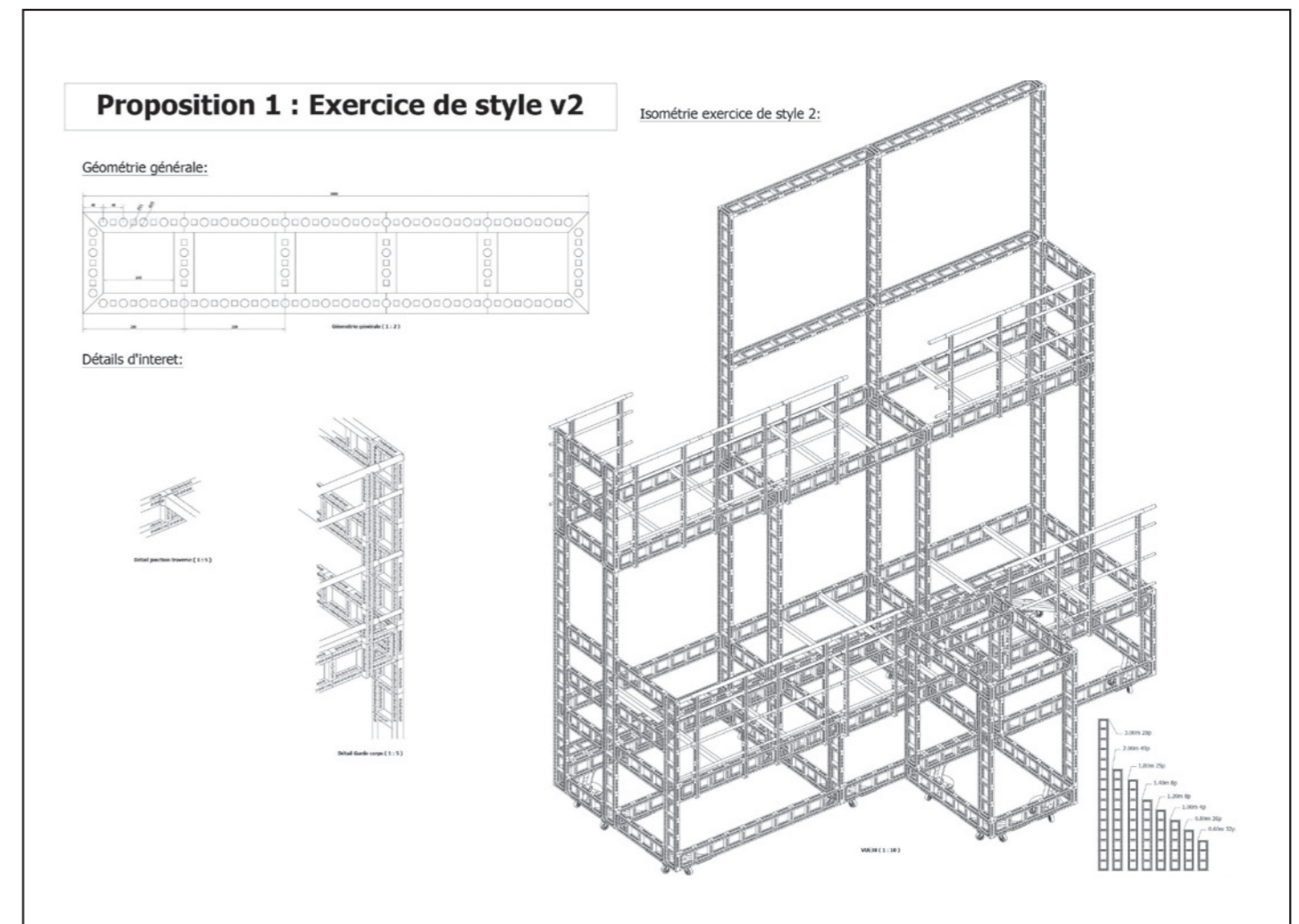

→ Style exercise — Phase 2 — COREF

# 02 | MOD 200 system

## Bars and trusses

The proposed modular system is based on the creation of a **family of linear elements (1D elements)**, called "**bars**", which can also be assembled into **lattice beams of specific lengths**, called "**trusses**" (2D elements).

The bars consist of a **closed profile (tube)**, regularly **perforated** according to the module grid, allowing:

- ↳ **mechanical connection by bolting**
- ↳ **significant reduction in the weight** of the elements.

The **cross-section of the profile** and the **centre-to-centre distance between the holes** are related to the module by the equation  $200\text{mm} / 5 = 40\text{mm}$ . This relationship allows the assembly of components that are rigorously established and constrained on the modular grid. **The CAD files and mechanical characteristics** of the licensed version are authoritative for their use.

## Profile/material

Common uses in set workshops have made it possible to quickly evaluate the **basic profiles** and **material** suitable for the system.

Taking into account rigidity, mass, weldability, supply costs and the ecological footprint of production, technical experts agreed on the use of **standard structural steel (EN 102191 standard)**, rather than aluminium, whose increasing use has a higher environmental impact.

The **main structural member** and **end uprights** are specified as **40 × 40 × 2 square tubing — S235JRH**. This **modular** section offers significant advantages for three-dimensional assemblies. The **intermediate uprights**, also known as "**pillars**", are made of **80 × 40 × 2 rectangular tubing — S235JRH**. The increased width, located in the beam plane, offers more connection possibilities while remaining **modular**.

The **diagonals** are made of **30 × 30 × 2 square tubing — S235JRH**. The use of diagonals for bracing more structural beams and their cross-section does not affect compliance with the module.

## Cutting and drilling

To ensure **precision in terms of length and drilling**, **laser tube cutting (CO<sub>2</sub> or fibre)** is used.

This process enables:

- ↳ cutting to length
- ↳ the creation of tenons and mortises for positioning intermediate uprights
- ↳ simultaneous drilling of the four sides of the tubes.

Outsourcing this operation is now widespread in the industry and effectively complements **flat laser cutting**, which is already widely used in set construction. The tolerance observed is typically  $\pm 0.1\text{ mm}$ .

The expansion phenomena observed during the research led to an **adjustment of the precision targets**, without compromising the specifications.

The lengths, multiples of 200 mm, are **modular and deliberately limited**. A specific length — **920 mm** — is introduced to allow modular repeatability in all axes. The maximum length of a component is set at **4,000 mm**, in line with: the lengths available in raw materials and the capabilities of the cutting machines.

## Assembly and relief holes

On the module grid, the **assembly hole** is set at  $\varnothing 12.4\text{ mm}$  (round).

This allows for:

- ↳ standard assembly in **M10**
- ↳ more precise assembly in **M12** if desired
- ↳ compatibility with various surface treatments.

The relief hole is defined as:

- ↳ **11 mm square, with a radius of 1 mm**

It also allows for **quick attachment of accessories**, in particular using bolts **TRCC M10 (DIN 603)** secured by their collars during rotation, facilitating tightening with a single wrench. After evaluating typical assembly cases, the drilling sequence starts with the **round hole at the centre of the upright**, 20 mm from the end of the MOD 200 element.

On the **intermediate uprights** specific holes are added :

- ↳  **$\varnothing 52\text{ mm}$  round hole**, allowing the passage of standard  $\varnothing 50\text{ mm}$  tubes,
- ↳ **Oblong hole** facilitating so-called "**sandwich**" assemblies requiring longer screws.

Finally, feedback from **the workshops has enabled us to optimise the tenons and assembly kits** of the intermediate uprights to simplify manufacturing and improve positioning reliability. These optimisations have been incorporated into the **available CAD cutting models**.

## Truss families (2D components)

The mechanically welded frame of the **lattice beam**, known as a "**truss**", consists of:

- ↳ **two structural members**, upper and lower
- ↳ connected by **two end uprights**
- ↳ creating a frame divided by **intermediate uprights**
- ↳ and optionally supplemented by **diagonal bracing**.

The **intermediate uprights** are distributed along the beam according to the **200 mm module grid**. Two **two-dimensional (2D) families** of trusses have been developed:

### MOD 200-200

- ↳ Beams **without diagonals**
- ↳ Height: **200 mm**
- ↳ Intended for **most common uses**.

### MOD 200-400

- ↳ Beams **braced by diagonal braces**
- ↳ Height: **400 mm**
- ↳ Designed for **structural applications requiring increased strength**.

**The proposed catalogue** covers most of the scenarios identified during the research.



→ 1D Element — Version 1 of MOD 200 © Christelle Calmettes



→ 2D Element MOD 200-200 — Version 1 of MOD 200 © Christelle Calmettes



→ 2D Element MOD 200-400 — Version 1 of MOD 200 © Christelle Calmettes

1D Element (bars): MOD Ø40 and MOD Ø40 H

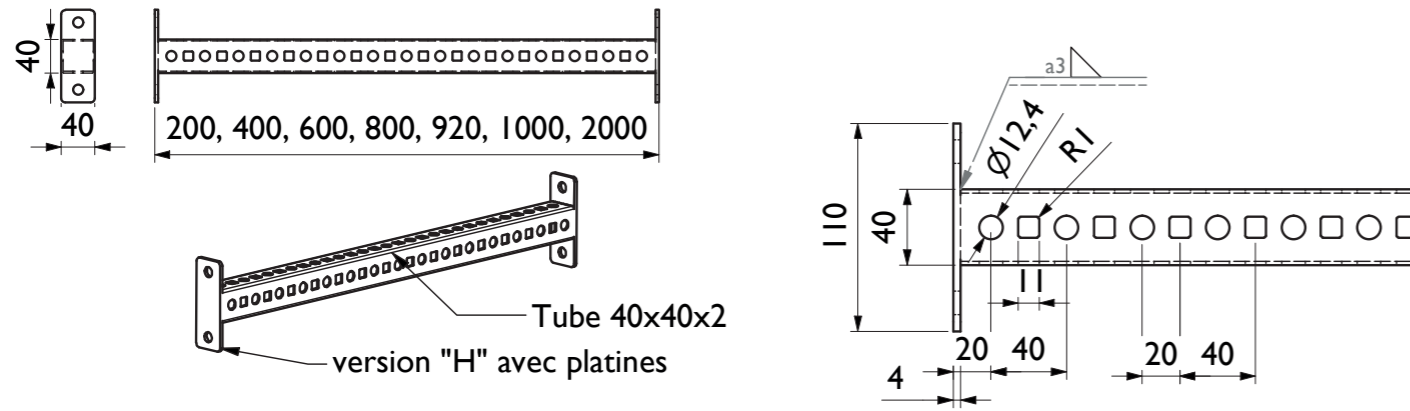

2D Element (trusses): MOD 200-200

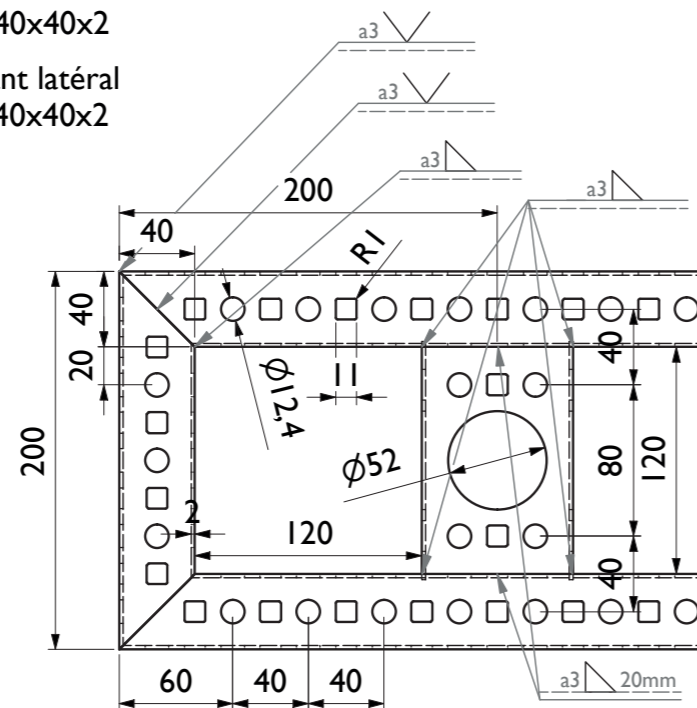
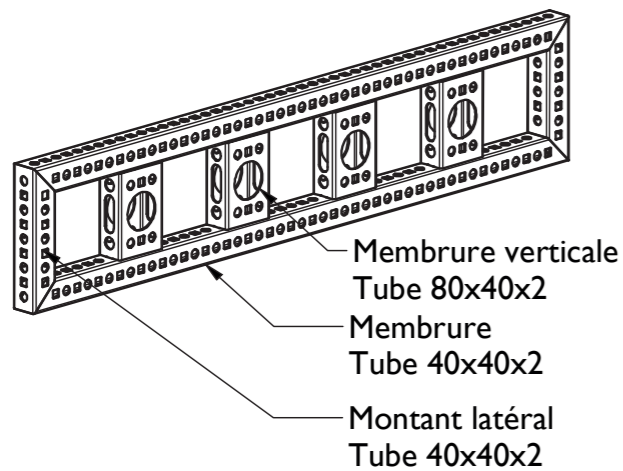
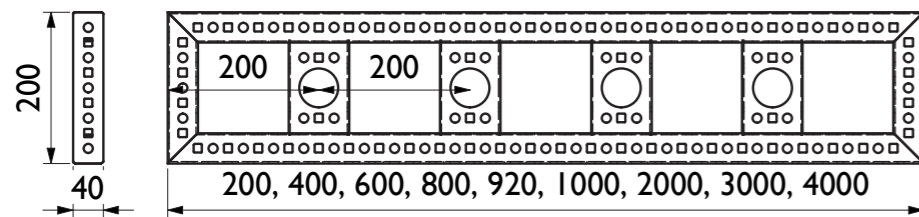

2D Element (trusses): MOD 200-400

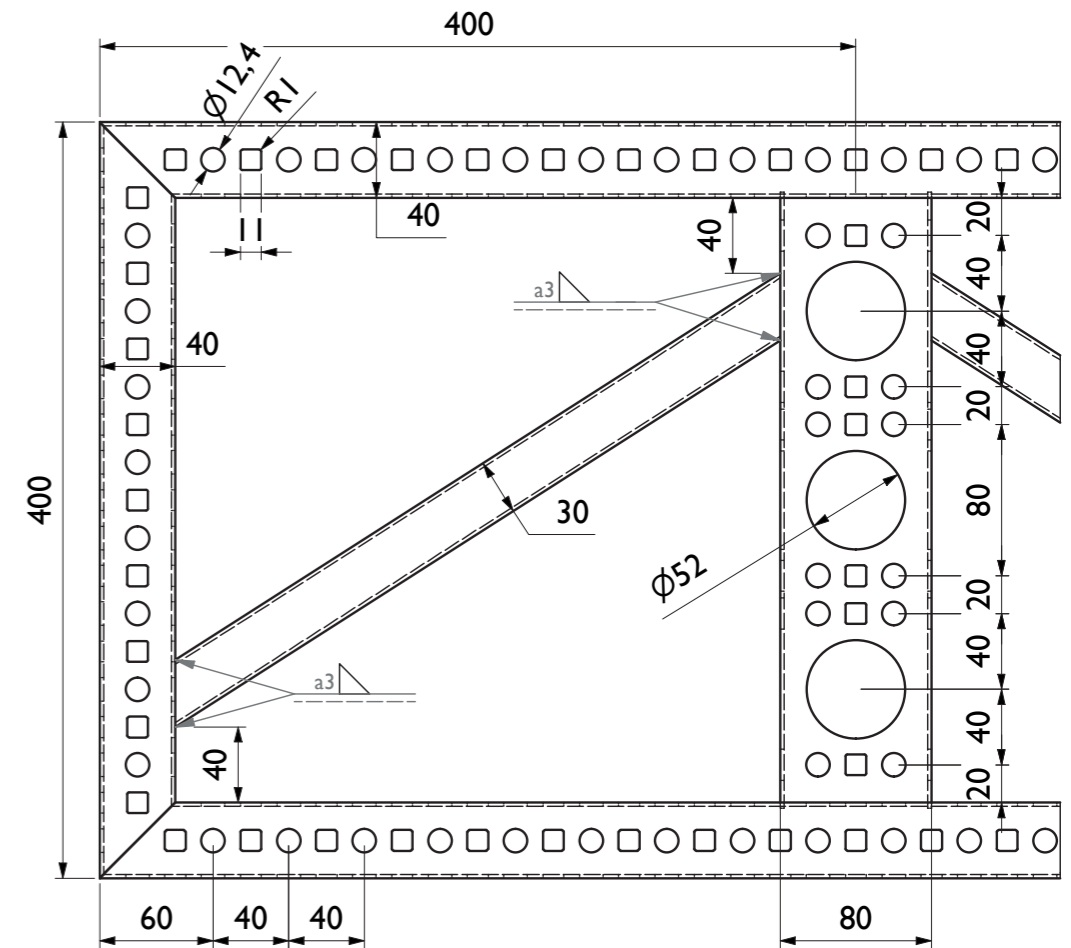
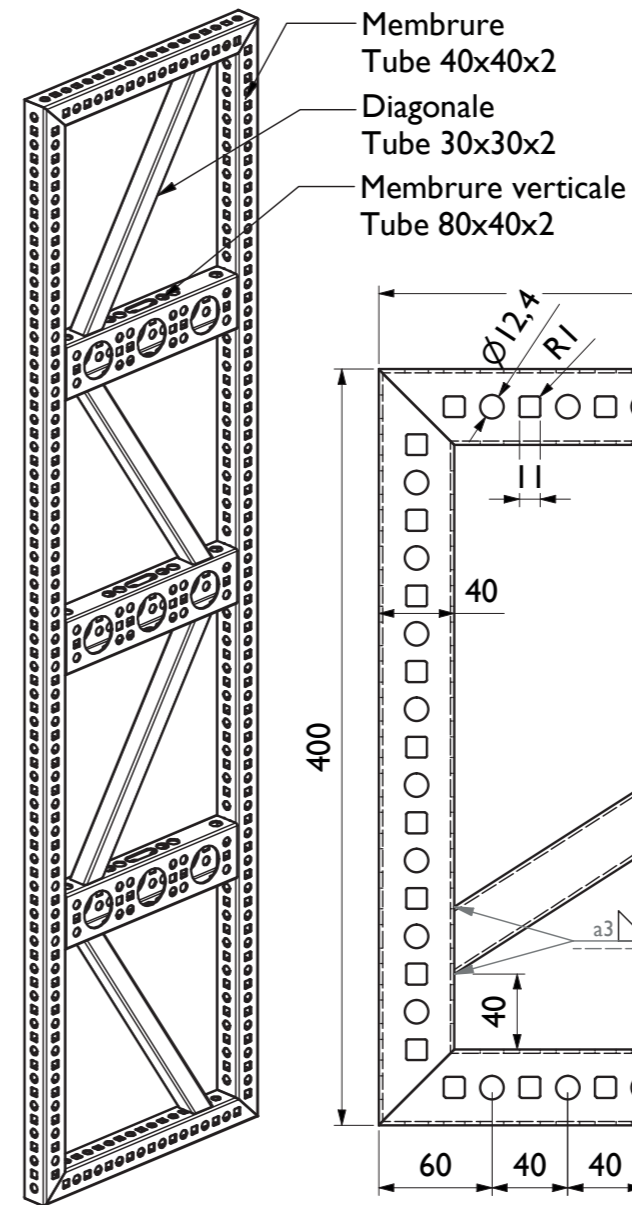
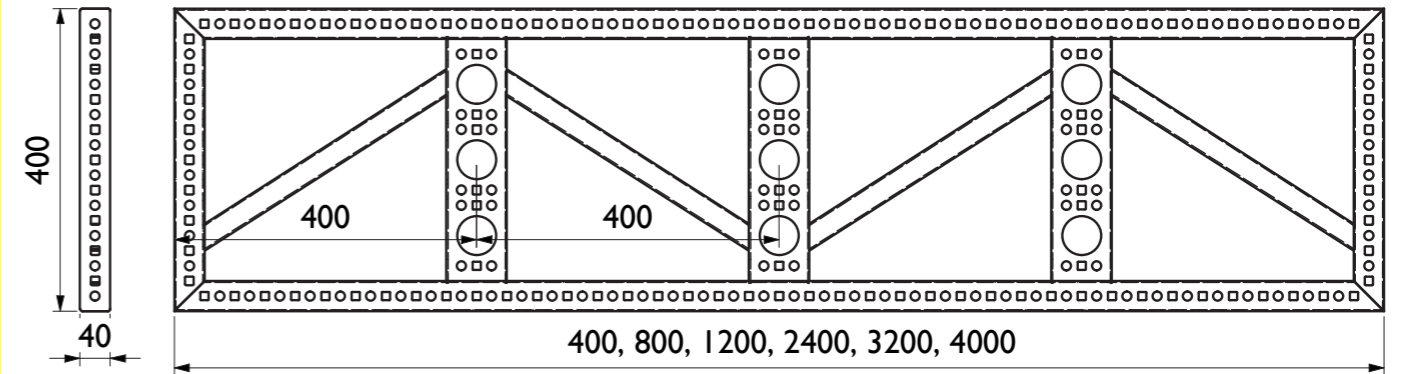

## General Set Construction Principles

- The accurate implementation of components in a structural assembly is based on the **following assumptions**:
- ↳ the **forces applied are identified** and characterised (uniform or point loads)
  - ↳ **torsional forces**, which are rare and unfavourable, must be **avoided**: the assembly must prevent their occurrence by:
    - ↳ **triangulation** of components
    - ↳ or **clamping** certain elements
  - ↳ the **overall stability of the structure** is studied and described
  - ↳ bracing, embedments and types of connections are defined
  - ↳ **fasteners, hangers and ballasts** are correctly dimensioned accordingly
  - ↳ the **calculation validates the permissible stresses and deflections**, which must be applied in accordance with the regulations in force (*Eurocodes and applicable standards*).

## Accessories

Accessories complement the MOD 200 system and allow it to be adapted to specific uses.

One of the strengths of the MOD 200 and the grid is the ability to create a wide range of reusable accessories: base plates, caster supports, lifting components, bracing accessories, etc.  
→ Next page: examples of accessories

### Folded brackets

### Lifting brackets

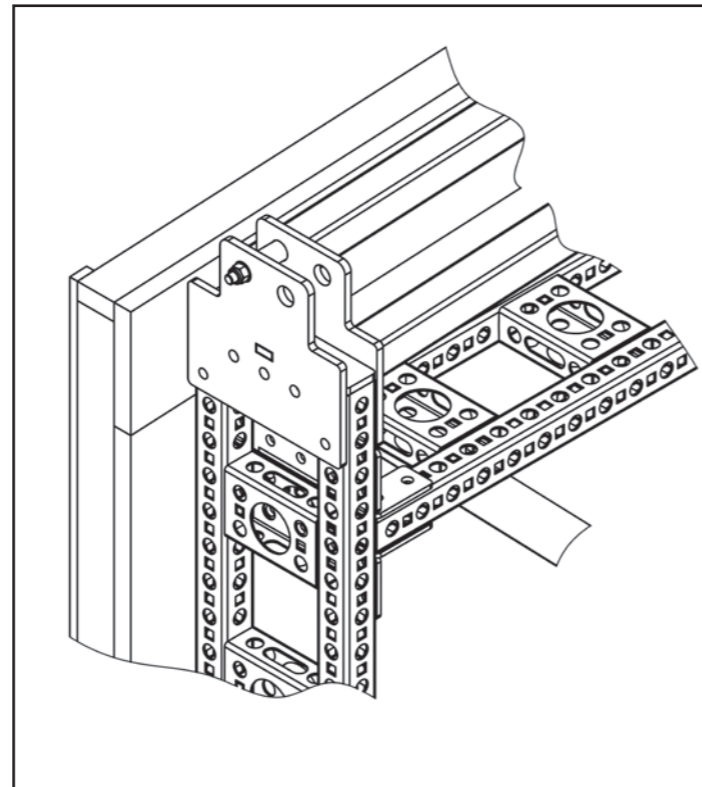

→ Example of accessory detail — Lifting shackle bracket  
© Jean-José Morra

### Bridges – 3D components

At this stage of research, although a **specific need** has been identified, **truss-type components** have not been specifically developed.

Their design, for applications such as posts, lintels and suspension elements, could eventually **complement the existing catalogue**.

This option remains open but is **not part of current developments**.

## MOD 200: Examples of Accessories 1/10

### Mounting plates

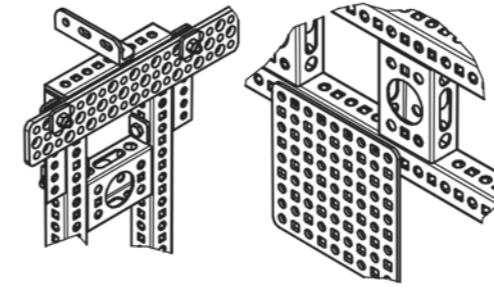

### Bracing accessories

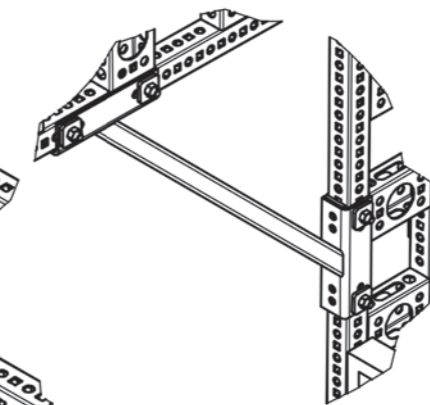

### Lifting accessories

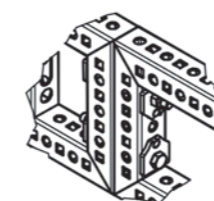
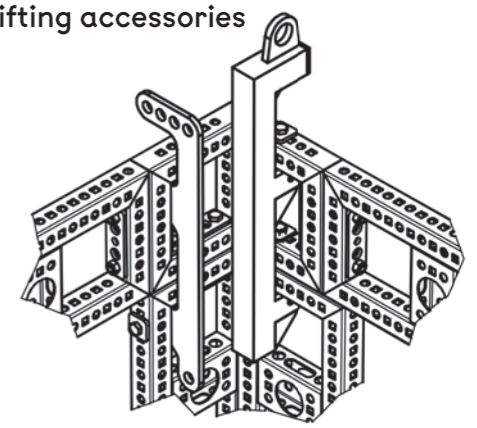

### Caster supports

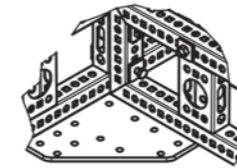
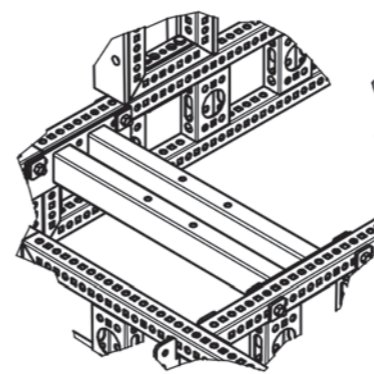

### 50mm tubing between frames

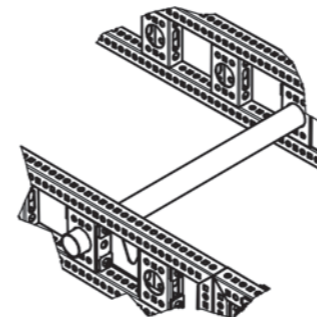

### Batten support

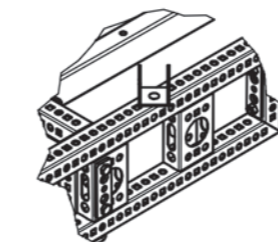

### Removable fittings

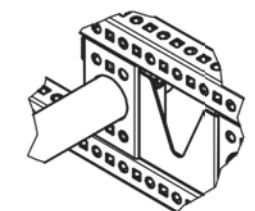
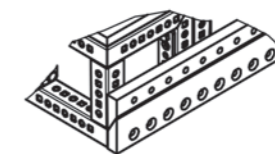
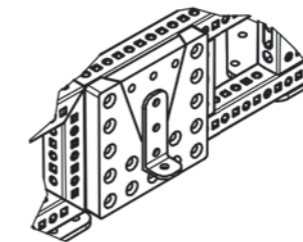

## Assembling

### Assembly hardware

Stage sets are, by nature, **designed to be assembled and disassembled**, sometimes many times during their life cycle. The **MOD 200** system is designed with **long-term use** in mind, both from a mechanical and maintenance perspective.

- After numerous evaluations, the **assembly fasteners** selected are in line with **current industry practices**.
- **Metric M10 bolts** are used as the **standard assembly fasteners**.
- The system **can also be assembled in M12** for applications requiring increased alignment precision.

The **strength class of the fasteners** is not specified: it is **not a determining factor** under the intended conditions of use.

### Assembly procedure

When assembling **large units**:

- it is recommended to carry out a **pre-assembly without tightening**
- **final tightening** should only be carried out after:
  - the entire unit has been assembled, if possible
  - checking for flatness
  - checking for misalignment and squareness.

This approach ensures **even distribution of clearances** and prevents **cumulative misalignment**.

### Tightening torque

The **recommended tightening torque for M10 bolts** is: **25 to 30 Nm**, so as not to deform the tube walls.

### Washers and force distribution

The use of a **thick washer or distribution plate** is strongly recommended in order to:

- prevent crushing of the tube walls,
- distribute the forces at the joints.

The recommended washer or distribution plate should be large in diameter ( $\varnothing$  37–40 mm) and have a minimum thickness of 2.5 mm, or be custom-made by cutting or stamping from thicker sheet metal. Tests show that **without these devices, the performance** (flexibility and strength) **is significantly reduced**.

### Assembly indicators

**Guides, positioning wedges, assembly indicator or spacers** can be incorporated in order to:

- facilitate assembly,
- secure the positioning of components deemed critical.

## Hybridisation

When the **MOD 200** cannot fully meet scenographic requirements (*non-orthogonal biaxiality, curved elements, curves, warped plates, etc.*), **specially designed elements** can be **used in conjunction** with the modular structure.

For optimal integration, these hybrid elements will be:

- designed on a **200 mm modular grid**.
- lined with the **40 mm** derived drilling grid.

## Assembly principles

The components can be assembled in the three orthogonal dimensions.

### Case of beams made from assembled lengths

For these assemblies, which allow for long spans or bearings when there is a shortage of long components in stock, it is preferable to avoid, where possible, **cantilevered assemblies** (without intermediate columns). Tests show that an assembled beam has **2 to 3 times less strength** than a continuous beam; **this type of assembly is therefore not recommended** and must be carefully assessed when it cannot be avoided.

### Typical joint

The following situations are **examples of joints**:

- bolted connection in **two axes without interference**
- bolted joint of several thicknesses (sandwich type)
- corner assemblies
- use of the **920 mm** element to allow compliance with the insertion module between two uprights
- assembly of **vertical trusses on a horizontal base**
- squaring pieces and braces.

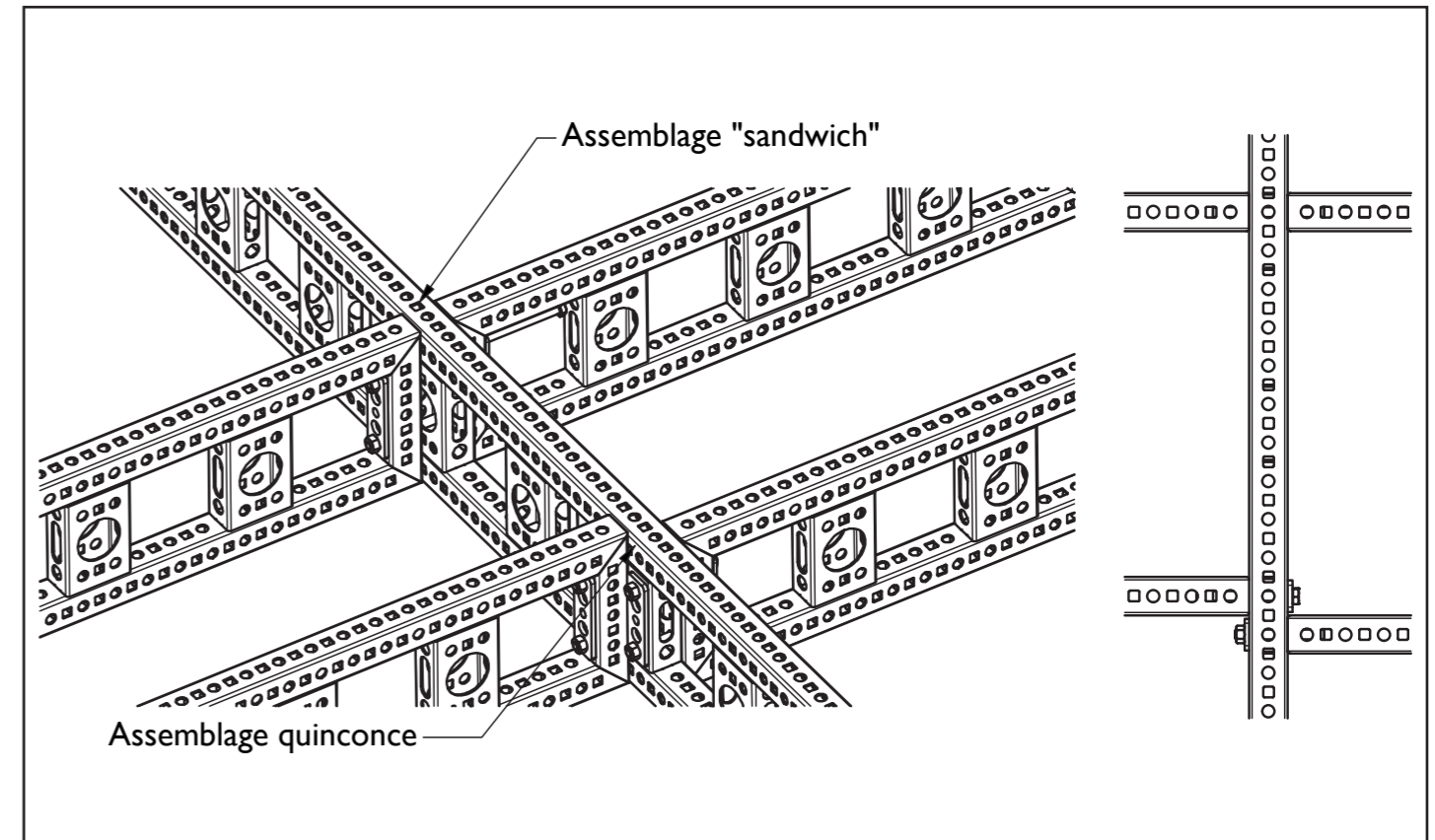

→ Sandwich-type assembly and Staggered configuration assembly, 1/10 © Thomas Lauret

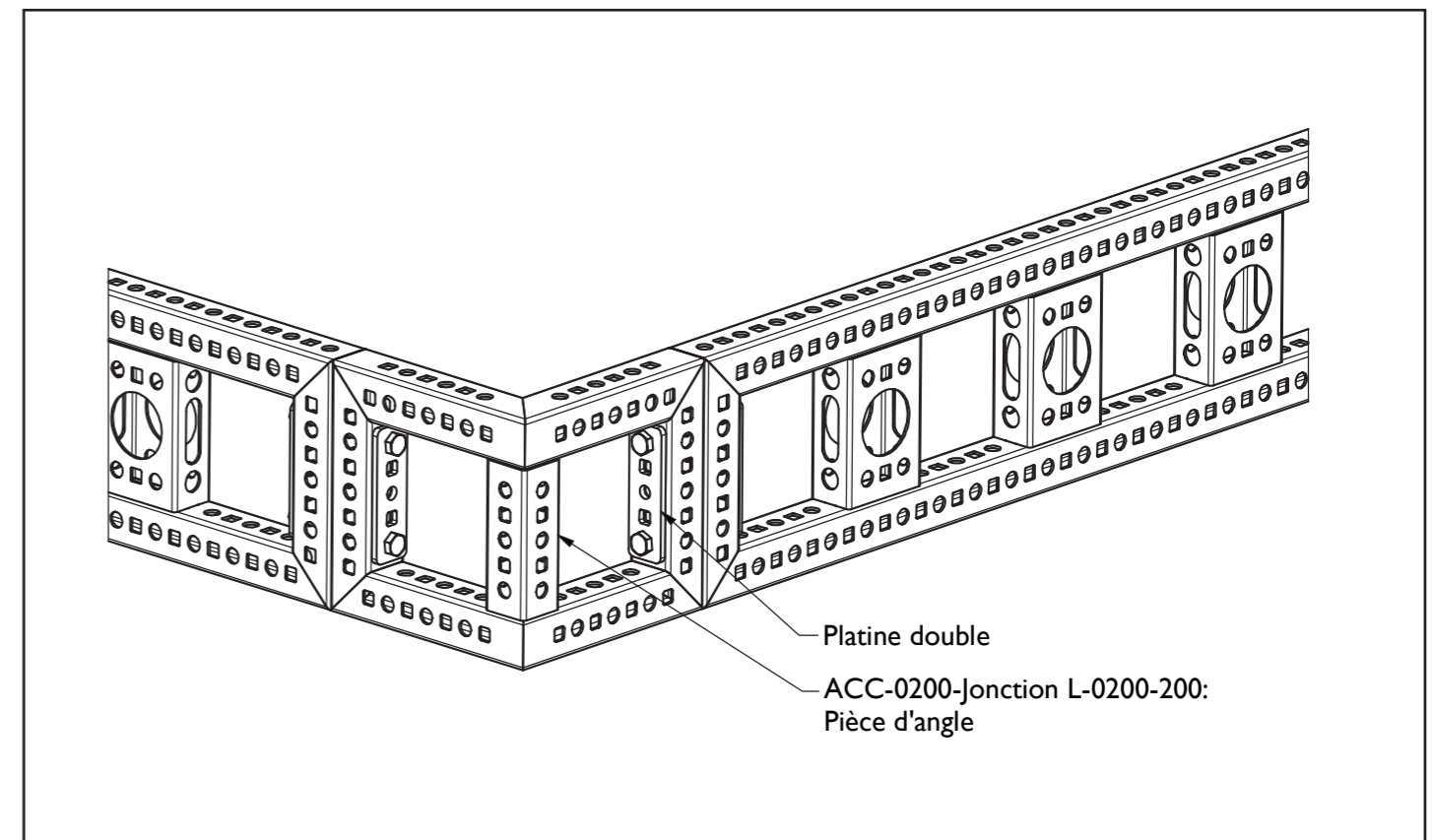

→ Assembly with double base plate and corner piece 1/10 © Thomas Lauret

# 05 | Dimensioning/Calculation

## Characterisation study

The **final mechanical characterisation** of the MOD 200 system is entrusted to an **independent, specialised design office**.

It is based on mechanical calculations, with a view to applying Eurocodes 3.

The methodology combines:

- ↘ analytical calculations (beam theory)
- ↘ numerical calculations (*finite elements — beams, shells and volumes*)
- ↘ **non-destructive and destructive** load tests
- ↘ comparative analysis between experimental and theoretical results.

This characterisation enables:

- ↘ **calculation of the complete mechanical characteristics of the profile**
- ↘ **determination of equivalent sections** for preliminary dimensioning
- ↘ creation of **load tables and charts** accessible to a wide audience (*design offices, workshops, platform trades*)
- ↘ a design approach **based on deflection or stress**, depending on the application.

A "**Good Practice Calculation Manual**" enabling the catalogue to be used for analytical or finite element calculations (beam model) is provided at the end of the study and is available.

## Tables and charts

### Quick uses and load cases

The use of load charts:

- ↘ does not exempt users from **complying with regulatory requirements**
- ↘ nor the **required qualifications**, particularly with regard to lifting.

These tools are designed by analogy with the **standard charts used in the events sector**, which are widely used for aluminium trusses.

### Contents

- ↘ maximum load tables;
- ↘ graphical charts:
  - ↘ rigidity (deflection)
  - ↘ strength (under stress)
  - ↘ for quick determination of the required profile
  - ↘ design assistance

## Mechanical characteristics

The **complete mechanical characteristics** of the MOD 200 system will be available to the public. They form the reference basis for any **modelling, justification or verification** of structures created using the MOD 200 catalogue. **Equivalent sections** are calculated and provided, enabling **simplified calculation in beam elements**, particularly using **free software** such as **RDM7** and the "**Good Practice Calculation Manual**".

Based on the **fundamental principles of MOD 200**, and reiterating in particular the **prohibition of torsional forces**, this manual lists several **calculation methods** corresponding to different performance levels:

- ↘ pre-dimensioning,
- ↘ dimensioning,
- ↘ verification.

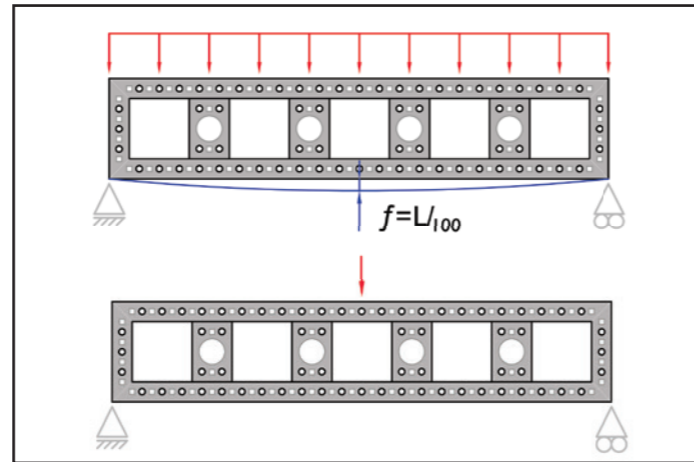

→ Allowable Point and Distributed Load Tables

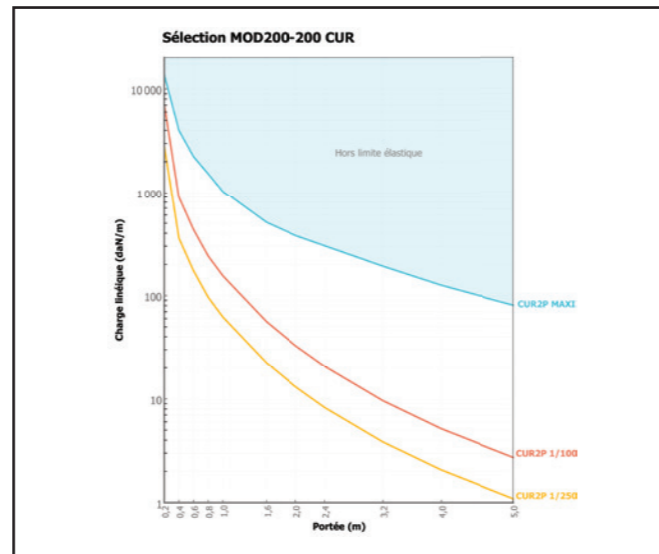

→ Table and standard chart (illustrative data — do not refer to)

# 06 | Manufacturing

The manufacture of MOD 200 components is designed to be **accessible to any metalworking workshop** with at least:

- ↘ flat surfaces or **assembly benches**
- ↘ **MAG welding station**

## Regulatory framework

At the date of publication, MOD 200 assembled trusses — like dedicated stage set constructions — **do not claim compliance** with the following standards:

- ↘ **NF EN 1090 2 + A1**
- ↘ **NF EN ISO 13920**

However, their design does not prevent them from being brought into compliance at a later date.

The digital manufacturing files guarantee:

- ↘ **precise positioning** of structure members and uprights,
- ↘ reliable **welding**, subject to compliance with best practices.

**Functional clearances** are designed to ensure the reproducibility of cuts and compatibility between service providers, regardless of the orientation of the profile in the cutting machine.

*Please note that these cutting processes are not subject to any tolerance standardisation. The Collective 17h25 cannot guarantee the results of future service providers and strongly recommends producing samples in order to calibrate the machines and adjust the assemblies before placing any large orders.*

## Marking

The **final manufacturer is responsible for the finished product**.

It is strongly recommended that **components be permanently marked with:**

- ↘ legible identification
- ↘ serial and/or batch number, to facilitate **traceability and maintenance**.

## Manufacturing recommendations

The Collective, confident in the expertise of professionals in the sector, nevertheless recommends:

- ↘ **systematic verification** of dimensions, flatness and squareness
- ↘ a minimum of **three complete welds per assembly**
- ↘ **thin and regular internal welds** on the external uprights
- ↘ to ensure proper support for the washers
- ↘ **side welding of the pillars from the inside**
- ↘ with the torch passing through the **Ø 52 mm** opening
- ↘ **careful grinding** of external surfaces and sharp edges.

### MOD 200-200 specifications

- ↘ the **tenons** are present on **only one end** of the intermediate member
- ↘ they fit into the first member, facilitating the assembly of the second

### MOD 200-400 specifications

- ↘ two **diagonal tenons** are positioned at the ends of the intermediate upright
- ↘ the **offset of the bracing (40 mm)** must be strictly observed in order to allow longitudinal assembly.

### Surface treatments

The following treatments are compatible with the MOD200 system:

- ↘ **thermal lacquering** (electrostatic powder coating)  
Single or double-layer treatments
- ↘ **liquid paint**  
Single or double coat treatments
- ↘ **electrogalvanising**  
plausible — not tested at this stage
- ↘ **hot-dip galvanising**  
Not recommended, due to zinc overload which may interfere with assembly and dimensioning

## Costs

As cost data **quickly becomes obsolete**, no reference values are presented at this stage. However, manufacturing costs are similar to those of purchasing a professional commercial aluminium ladder.

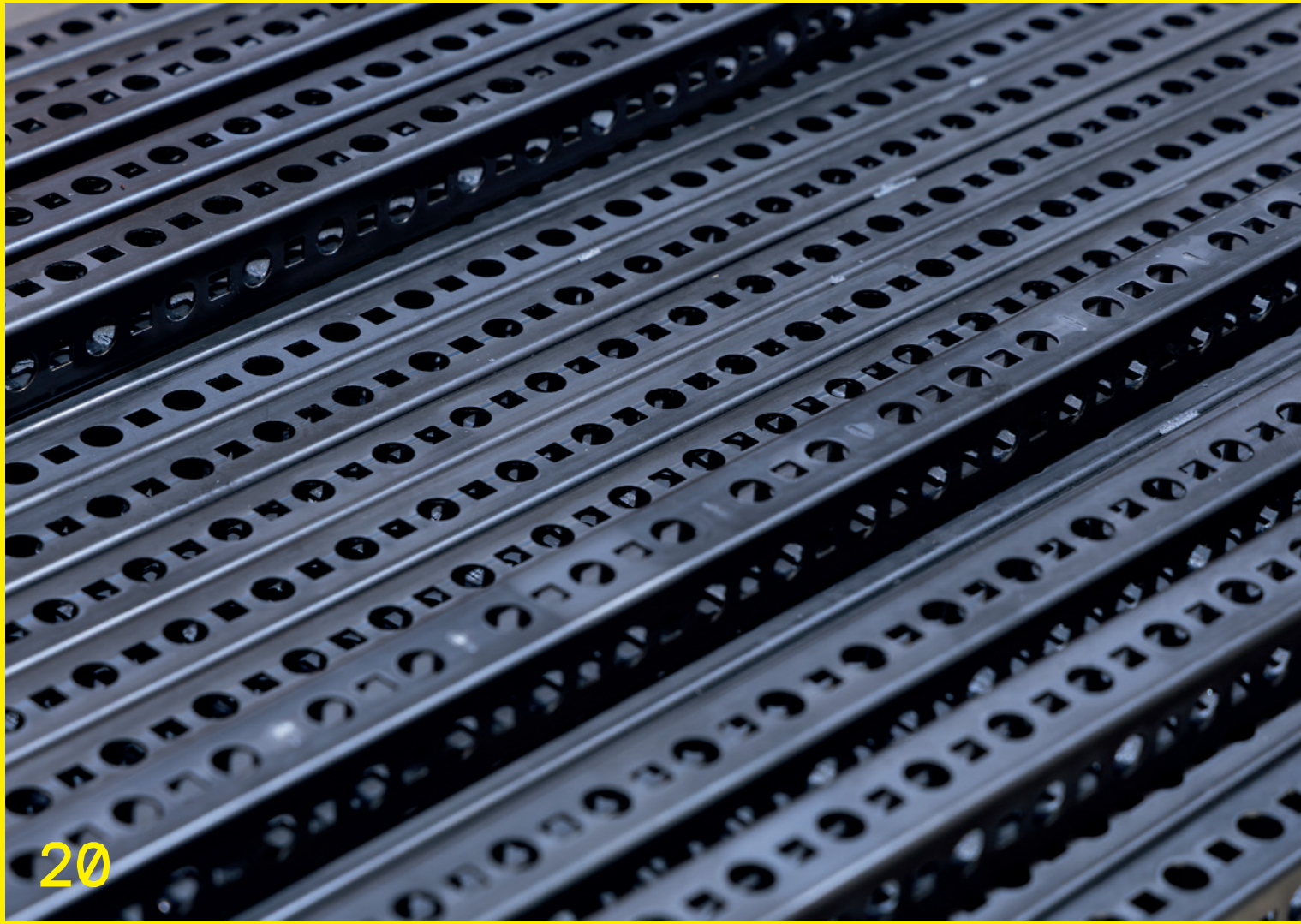

## 07 | Control/Maintenance

The Collectif 17h25 has not conducted any specific research on maintenance procedures. No detailed recommendations are therefore made at this stage.

Any **damage observed** requires:

- ↳ either a **repair**
- ↳ or **decommissioning** of the affected component

These checks must be carried out by a **qualified technician**.

## 08 | Storage/Sharing

Feedback does not yet allow for detailed technical recommendations to be made.

Nevertheless, the Collective encourages the **creation of shared platforms**, promoting:

- ↳ a sharing of stocks
- ↳ a reduction of redundant manufacturing
- ↳ a reduction in transport.

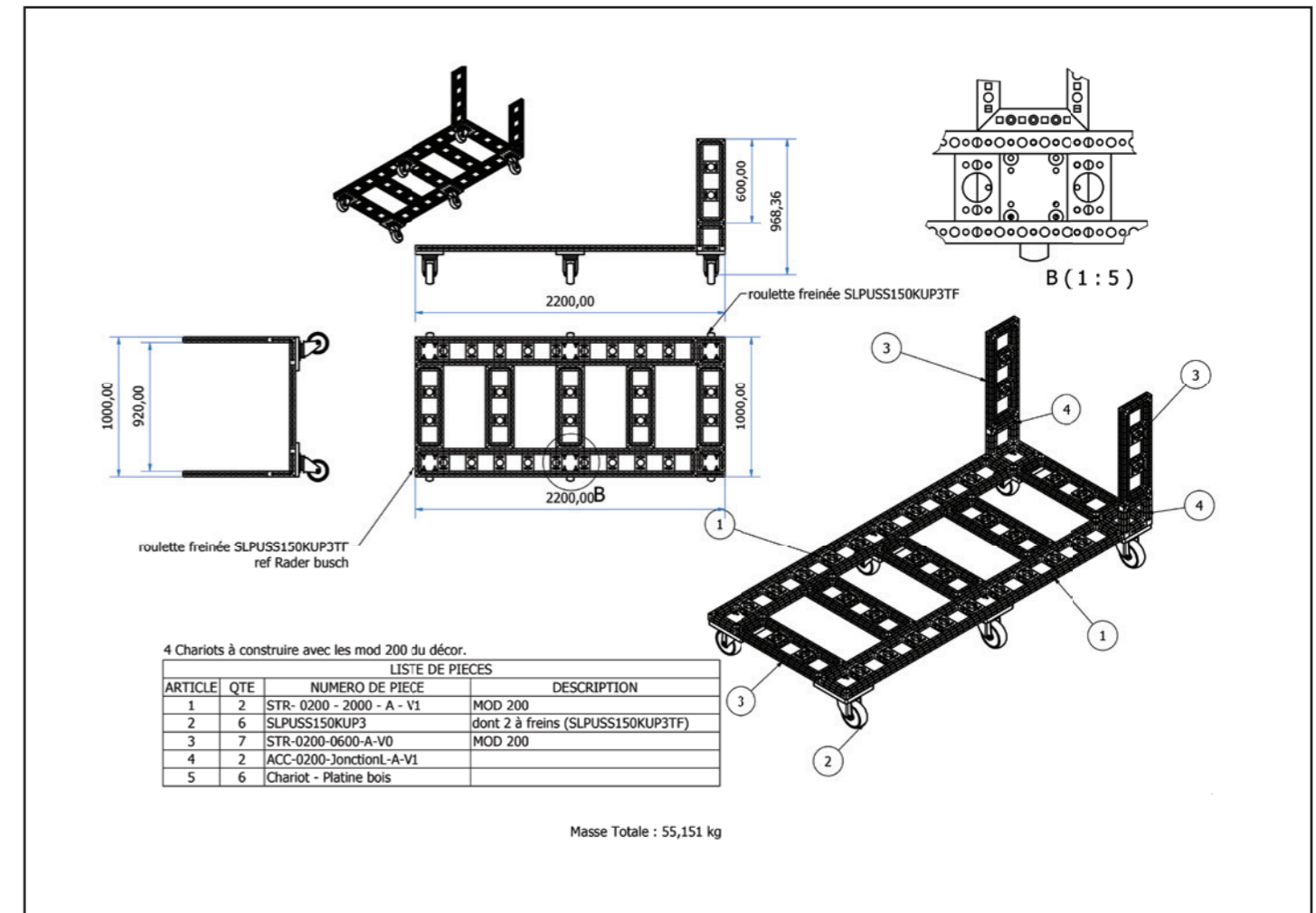

→ Rolling trolleys made using MOD 200 © Thomas Lauret

← Positioning of profiles before welding © Christelle Calmettes  
 ← Detail of laser-cutting process for MOD 200 tubes — Version 1 © Christelle Calmettes

# Conclusion

## The MOD 200 system is a collective, open and scalable response to the technical, environmental and organisational challenges associated with set construction.

Resulting from collective intelligence research, it offers:

- ↳ a standardised modular framework
- ↳ shared design, calculation and manufacturing tools
- ↳ a logic of reuse and pooling, while respecting freedom of set creation

The purpose of this booklet is to:

- ↳ document the technical and methodological foundations of the system
- ↳ share best practices resulting from experimentation
- ↳ make directly operational resources available
- ↳ and enable gradual adoption by all stakeholders in the sector.

MOD 200 is set to evolve, to be enhanced with new uses, and to adapt a variety of contexts, based on contributions, feedback, and future developments driven by the MOD 200 community.

The Collectif 17h25 invites all users to take advantage of the tools on offer, share their uses, and contribute to their improvement, in a joint effort to reduce impacts, pass on know-how, and share responsibility.

# FAQ — MOD 200

## ► Who is the MOD 200 system for?

MOD 200 is mainly intended for:

- ↳ **design offices**
- ↳ **set construction workshops (performing arts, museography, cinema, etc.)**
- ↳ **machinists and stage crews**
- ↳ **technical managements**

but also any organisation involved in the **design or manufacture of stage sets** wishing to adopt a policy of **reuse, standardisation and impact reduction**.

## ► Does the MOD 200 limit creative freedom in set design?

No. The MOD 200 is designed to be used mainly **behind the scenes**, without restricting the shapes, materials or finishes visible to the audience.

When certain scenographic intentions cannot be fully achieved by the modular system (non-orthogonal geometries, curves, curved elements, etc.), **hybrid elements in dedicated construction** can easily be integrated.

## ► Does the MOD 200 replace all dedicated structures?

No. The MOD 200 does not claim to be a solution for all situations, but aims to:

- ↳ **significantly reduce** the use of dedicated structures
- ↳ **limit their repeated manufacture**
- ↳ **reduce the volumes transported**, particularly for touring and co-productions.

## ► Is the system suitable for touring and co-productions?

Yes, that is one of the **main objectives** of the project.

MOD 200 aims to:

- ↳ **pooling stocks**
- ↳ **reduce transport**
- ↳ ensure **component compatibility** between venues.

Ultimately, The goal is to **make the transport of structures themselves obsolete**.

## ► Why is the MOD 200 made of steel?

The choice of steel is the result of **environmental, technical and operational considerations** based on research and initial **Life Cycle Assessment (LCA)** results.

- ↳ From an environmental perspective, LCA comparisons between steel and aluminium show that, despite its higher mass, steel has:
  - ↳ a **lower impact during extraction**
  - ↳ a **better structured and more efficient recycling system**
  - ↳ better performance in **multiple reuse** scenarios, which is at the heart of the MOD 200 project.
- ↳ From an industrial standpoint, steel manufacturing:
  - ↳ is **accessible to most set construction workshops**
  - ↳ requires **standard equipment** and **lower investment**
  - ↳ relies on **skills** that are **widely available** in the sector.
- ↳ In terms of manufacturing, steel offers:
  - ↳ **greater dimensional stability** during welding
  - ↳ fewer deformation issues than aluminium under normal workshop conditions.
- ↳ In terms of risk prevention, the use of steel:
  - ↳ generates **potentially less toxic fumes** than certain aluminium alloys.

## ► Can MOD 200 be manufactured by any workshop?

Yes, under certain conditions.

Manufacturing is designed to be **accessible to most metalworking workshops** with:

- ↳ standard equipment (MAG welding, flat surfaces)
- ↳ proficiency reading of plans and CAD files
- ↳ access to a laser tube cutting service provider.

However, it is recommended to:

- ↳ make **samples** before mass production
- ↳ check machine settings
- ↳ strictly follow the recommendations in the booklet.

## ► Do the holes weaken the structure?

Yes, the **holes affect the mechanical behaviour** of the profiles: they alter the resistant section, rigidity and buckling resistance.

It is precisely for this reason that dimensioning of the MOD 200 system

- ↳ is **never based on theoretical solid sections**
- ↳ but on a **specific mechanical characterisation of perforated profiles**

The calculations use reference standards adapted to **perforated profiles**, in particular those from:

- ↳ the **NF EN 15512 standard** (annex concerning perforated systems)

- ↳ supplemented by the **applicable Eurocodes**

The determined **equivalent sections** explicitly incorporate the effect of holes and are **validated by testing**. The dimensions cover the **most common use cases** encountered in set construction (loads, spans, typical configurations).

## ► Why use M10 screws in Ø 12.4 mm holes?

The **Ø 12.4 mm** diameter is the result of a **deliberate compromise**, validated by testing and user feedback.

It allows for:

- ↳ standard assembly in **M10** with a typical clearance of approximately 2 mm
- ↳ the possible use of **M12** for applications requiring higher alignment precision, without modifying the components.

The functional clearance:

- ↳ facilitates repeated **assembly and disassembly** operations
- ↳ compensates for **manufacturing tolerances**
- ↳ takes into account **different surface treatments** (painting, powder coating, galvanising, etc.)
- ↳ reduces the risk of **jamming** on long assembled lengths

The final geometric precision is achieved:

- ↳ by **positioning** the **entire** assembly before final tightening
- ↳ rather than by the individual positioning of each component.

► **Is the system standardised or certified?**

The MOD 200:

- is not certified in the industrial standard sense (EN 1090, etc.),
- is based on a **complete mechanical characterisation** carried out by an **independent design office**.

The responsibility for dimensioning, implementation and use remains with the **professionals involved**.

► **Can the dimensions of MOD 200 components be modified?**

No. The **dimensions of standard components** (bars, trusses, profiles) are **fixed** and protected by a **CC BY-ND-NC 4.0 Creative Commons licence**.

However:

- the **development of accessories** is encouraged
- Combining MOD 200 with customised elements in **hybrid systems** allows for situations where **modular logic** cannot be fully applied.

► **Is MOD 200 compatible with lifting and suspension?**

Yes, provided that:

- the **dimensions** take into account specific load cases, particularly critical lifting situations (lifting by tilting, etc.)
- regulatory lifting qualifications** are met
- users are **trained** and competent.

The tables provided do not exempt users from complying with lifting regulations.

► **Who is responsible in the event of structural failure?**

Responsibility lies with:

- the **designer** (dimensioning)
- the **manufacturer** (manufacturing quality)
- the **installer** (assembly, use).

The Collectif 17h25 provides a **documented technical framework**, but cannot replace the legal and professional responsibilities of the parties involved.

► **Where can I find CAD files, charts and technical resources?**

The resources currently available are:

- plans, parts lists and catalogue images**
- CAD files for cutting**
- CAD files for modelling**
- charts and load tables**
- mechanical characteristics**
- the Good Practice Calculation Manual**
- application examples**
- plans and CAD drawings for certain **accessories**

<http://mod200.collectif17h25.org>



► **Can we contribute to the development of MOD 200?**

Yes, and we encourage you to do so.

The MOD 200 is a **collective and evolving project**.

Contributions can focus on:

- the development of accessories
- feedback
- implementation improvements
- sharing of use cases

The **MOD 200 community** is the ideal place for these exchanges.

# Project identity

**Project led by Collectif 17h25**

- Théâtre du Châtelet
- Opéra de Paris
- Opéra de Lyon
- Festival d'Aix-en-Provence
- Théâtre Royal de La Monnaie (Brussels)



**Technical service providers associated with the research**

- CEN.Construction
- Cortes Ingénierie
- EVEA

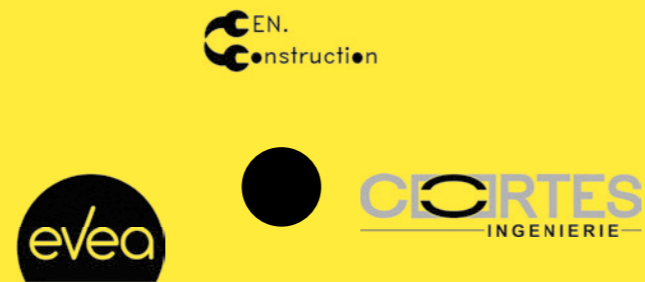

**MOD 200 - Grille, Catalogue & Nomenclature**

Traine 3D 200x200x200mm  
Structure d'épaisseur 40mm  
Trame des trous  
d'assemblage 40x40mm

Trous : assemblages : Ø 12,4mm boulons M10 ou M12 accessoires : Carré de 11mm

Pièce de jonction: évite les boulons apparents

Pièce de 920mm: Permet de rester dans le MOD 200 et métrique

**NOMENCLATURE:**  
Pour le standard Mod 200: STR-XXX-XXX (dimension 1 (mm), dimension 2 (mm))  
Pour les pièces accessoires: ACC-XXXX-Nomenclature-XXXX-XXX (appellation dimension 1, dimension 2, dimension 3)

**MOD 200**

STR-040-0200	0.65kg	STR-040-0400	1.04kg	STR-040-0600	1.42kg	STR-040-0800	1.82kg	STR-040-0920	2.05kg	STR-040-1000	2.20kg	STR-040-2000	4.15kg
STR-200-0200	1.29kg	STR-200-0400	2.40kg	STR-200-0600	3.50kg	STR-200-2000	11.53kg	STR-200-4000	22.26kg	STR-400-2400	18.79kg	STR-400-3200	24.90kg
STR-400-0400	3.52kg	STR-400-0800	6.57kg	STR-400-1200	9.63kg	STR-400-1600	12.69kg	STR-400-2000	15.75kg	STR-400-2400	18.79kg	STR-400-2800	21.84kg
STR-400-3200	24.90kg	STR-400-3600	30.96kg	STR-400-4000	37.02kg	STR-400-4400	43.08kg	STR-400-4800	49.14kg	STR-400-5200	55.20kg	STR-400-5600	61.26kg

